

PUFFER 1

HEATING WATER BUFFER TANK WITH 1 FIXED HEAT EXCHANGER



APPLICATION

Efficient storage of heating hot water mostly using biomass, heat pumps or solar thermal energy sources.

MATERIAL

Mild steel construction with exterior paint. No anti-corrosion treatment required due to the buffer's closed circuit system.

HEAT EXCHANGER

N° 1 mild steel fixed heat exchanger.

TECHNICAL DESCRIPTION

Used to improve flexibility of pellets, stoves and burners. PUFFER 1 are used in units with a typically discontinuous energy source such as biomass boiler and solar thermal system.

PUFFER 1 allows the solar energy system integration.

INSULATION

- HARD: High thermal insulation with ecological polyurethane hard foam.

- SOFT: NOFIRE® polyester fleece 100% made of recyclable material, with high thermal insulation. Fire resistance class B-s2d0 according to EN 13501.

Grey PVC external lining, complete with top and flange cover.

WARRANTY

5 years - See general sales conditions and warranty

ACCESSORIES AND SPARE PARTS

See Accessories section for the entire list.

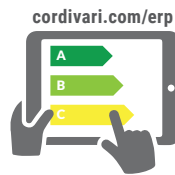

On line ErP label tool



PUFFER 1 VB

Model	HARD FOAM insulation		HEAT EXCHANGER SURFACE [m ²]	ENERGY EFFICIENCY CLASS ErP
	Art. Nr.	[m ²]		
300	3251162312201	1,0	B	
500	3251162312202	1,9	C	
600	3251162312203	2,1	C	
750	3251162312214	2,3	B	
800	3251162312215	2,5	B	
1000	3251162312216	3,1	C	
1250	3251162312207	3,4	B	
1500	3251162312208	3,8	C	
2000	3251162312209	4,6	B	



PUFFER 1 VB

Model	DISMOUNTABLE HARD FOAM insulation		HEAT EXCHANGER SURFACE [m ²]	ENERGY EFFICIENCY CLASS ErP
	Art. Nr.	[m ²]		
750	3251162312204	2,3	B	
800	3251162312205	2,5	B	
1000	3251162312206	3,1	C	



PUFFER 1 VC

Model	DISMOUNTABLE SOFT FLEECE insulation		HEAT EXCHANGER SURFACE [m ²]	ENERGY EFFICIENCY CLASS ErP
	Art. Nr.	[m ²]		
750	3251162282814	2,3	C	
800	3251162282815	2,5	C	
1000	3251162282816	3,1	C	
1500	3251162282817	3,8	C	
2000	3251162282818	4,6	C	
3000	3251162282308	6,2		
5000	3251162282309	7,5		

ACCESSORIES

THREEPHASE and MONOPHASE Electric immersion heaters

Available kit:		
[Kw]	Tension [V]	
da 1,5 a 3	220 - MONOPHASE	
da 4 a 12	400 - THREEPHASE	
See accessories		

Thermometer

Art. Nr.	
5032240000107	
5 units box	

Buffer tanks connecting kit

Art. Nr.	Connection	
5006170001001	1" 1/2	
Stainless steel extensible connecting kit - (200 ÷ 400 mm)		

PUFFER 1

HEATING WATER BUFFER TANK WITH 1 FIXED HEAT EXCHANGER

STORAGE		HEAT EXCHANGER	
Pmax	Tmax	Pmax	Tmax
3 bar	99 °C	12 bar	110 °C



CORDIVARI Lab

TÜV Rheinland Energie und Umwelt GmbH states that test procedures and Cordivari LAB are certified conforming to European standard EN 15332, as indicated by Ecodesign ErP Directive.

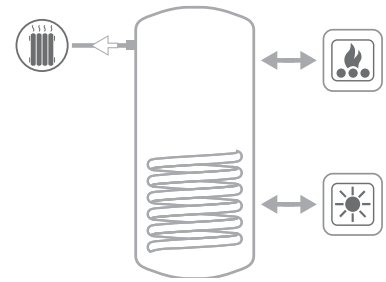

See TECHNICAL SUPPORT chapter for example of installation

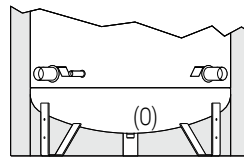
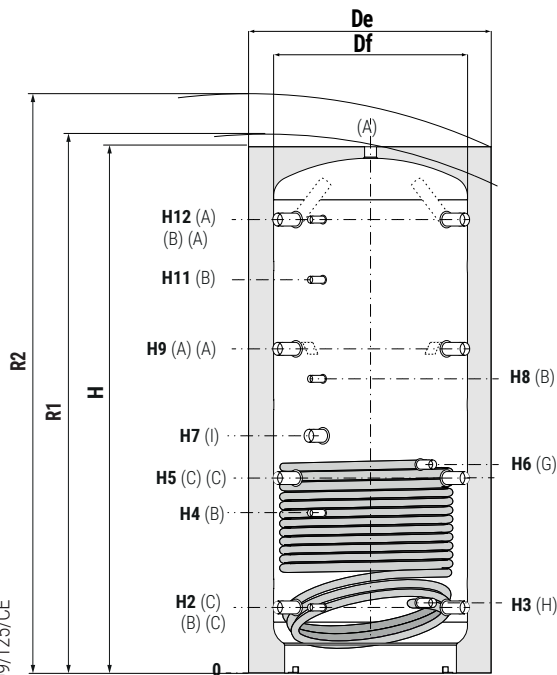

Standard supporting feet for models 3000 and 5000. Drain welded on the bottom.

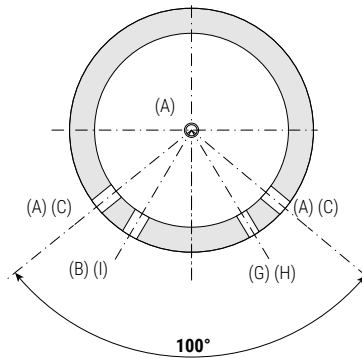

- A** Heating delivery/from generator
- B** Connection for instrumentation 1/2" F
- C** Heating return/to generator
- I** Connection for electric immersion heater
- G** Heat exchanger inlet 1" F
- H** Heat exchanger outlet 1" F
- O** Drain only for models 3000 and 5000

Model	Volume [lt]	Df (vers. VC)	De (vers. VC)	De (vers. VB)	H	R1	R2	H2	H3	H4
		[mm]		[mm]						
300	279	//	//	650	1340	//	1495	232	217	444
500	478	//	//	750	1620	//	1790	247	260	533
600	560	//	//	750	1870	//	2020	247	260	582
750	717	790	1010	950	1658	1665	1915	265	278	584
800	805	790	1010	950	1840	1845	2075	265	278	584
1000	946	790	1010	950	2130	2135	2340	265	284	656
1250	1248	//	//	1050	2201	//	2445	313	326	705
1500	1454	950	1210	1100	2250	2255	2510	313	336	736
2000	1973	1100	1360	1300	2320	2325	2665	347	370	770
3000	2915	1250	1450	//	2814	2820	3170	556	569	1017
5000	4985	1600	1800	//	2929	2935	3445	586	609	1047

Model	H5	H6	H7	H8	H9	H11	H12	A - C - I	O
	[mm]							Connections F	
300	514	514	590	725	796	885	1078	1 1/2"	//
500	629	745	841	930	1011	1231	1343	1 1/2"	//
600	695	855	915	1060	1144	1382	1593	1 1/2"	//
750	630	679	823	938	995	1180	1371	1 1/2"	//
800	690	762	823	988	1115	1332	1541	1 1/2"	//
1000	787	953	998	1188	1309	1588	1831	1 1/2"	//
1250	835	884	986	1168	1357	1568	1879	1 1/2"	//
1500	845	1006	1061	1286	1377	1653	1909	1 1/2"	//
2000	879	1001	1060	1300	1411	1687	1943	1 1/2"	//
3000	1071	1551	1693	1879	1786	2140	2402	2"	1"
5000	1101	1522	1691	1889	1816	2159	2432	2"	2"

P.E.D. product designed and produced in conformity to the article 4.3 of directive 2014/68/UE - ErP Ecodesign directive 2009/125/CE

PUFFER 1

LOWER HEAT EXCHANGER POWER

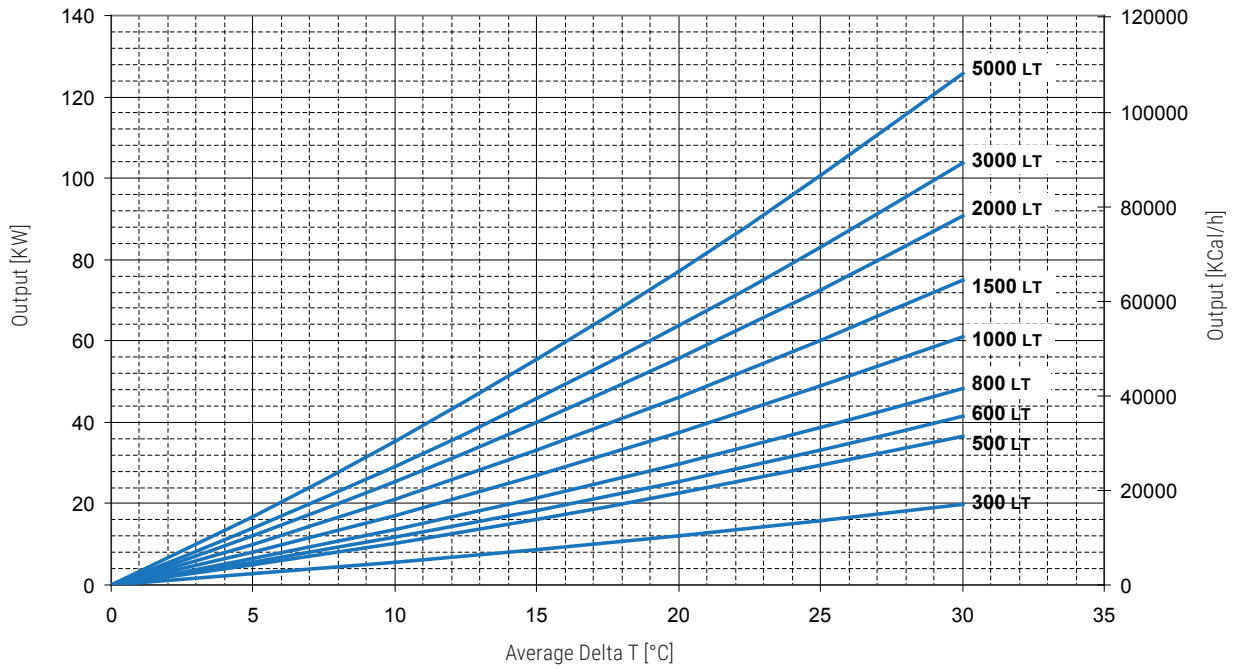

Thermal output is given in both kW or kcal/h in terms of average temperature difference between primary and secondary circuit, all for a range of primary 3 m³/h. For example, a PUFFER 1 T of 1000 liters capacity with a water flow of 3 m³/h at 80 °C inlet and outlet at 70 °C, has on the storage of water an average temperature of 60 °C, the main difference of temperature will be: (80 + 70) / 20 - 60 = 15 °C and therefore you can exchange up to approximately 34 kW.

Output of the lower heat exchangers PUFFER 1 depending on the average DeltaT between primary and accumulation considering flow rate 3 m³/h.

LOWER HEAT EXCHANGER PRESSURE LOSS

